

PF210S-6-10

1PH COMMERCIAL/INDUSTRIAL FILTER
DUAL STAGE / CHASSIS MOUNT

SPECIFICATIONS

MAX VOLTAGE: 0-300VAC

MAX CURRENT: 6A/LINE

USABLE FREQUENCY: 50/60/400HZ

OPERATING TEMP.: -40 TO 50C

LEAKAGE CURRENT (250V/60HZ): <1mA

TYP. WEIGHT, LB(KG): 0.45(0.2)

CLIMATIC CLASS: 25/100/21

DESIGNED AND MANUFACTURED IN ACCORDANCE

WITH THE FOLLOWING STANDARDS:

EN60939-3

CSA22.2 NO. 8

LV DIRECTIVE

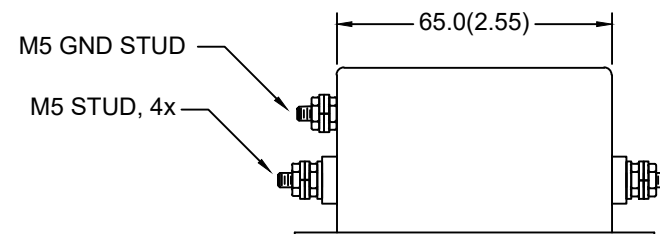
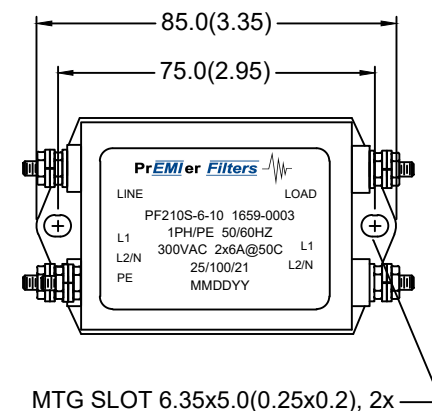
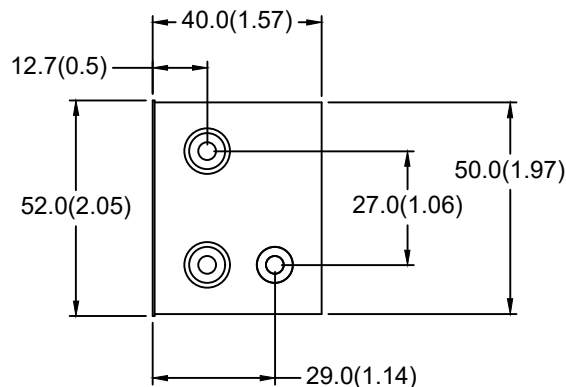

SCHEMATIC

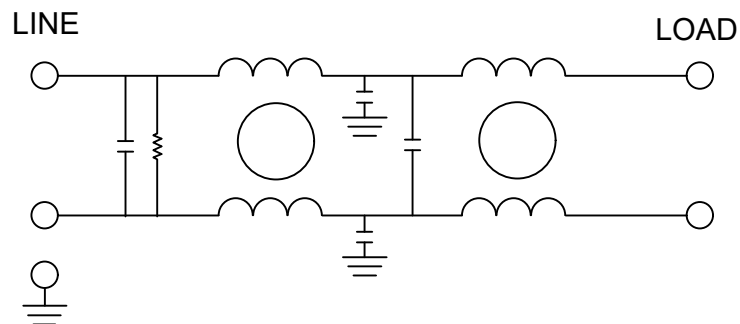

TYPICAL INSERTION LOSS, 50/50 OHM

FREQ(HZ)	150K	500K	1M	10M	30M
CM, dB	50	54	60	55	46
DM, dB	32	40	55	60	60