

PF403S-50-100

3PH WYE COMMERCIAL/INDUSTRIAL FILTER  
SINGLE STAGE / CHASSIS MOUNT

SPECIFICATIONS

MAX VOLTAGE: 0-520VAC  
MAX CURRENT: 50A/LINE  
USABLE FREQUENCY: 50/60/400HZ  
OPERATING TEMP.: -40 TO 50C  
LEAKAGE CURRENT (250V/60HZ): <1mA  
TYP. WEIGHT, LB(KG): 3.8(1.7)  
CLIMATIC CLASS: 25/100/21  
DESIGNED AND MANUFACTURED IN ACCORDANCE  
WITH THE FOLLOWING STANDARDS:

EN60939-3  
CSA22.2 NO. 8  
LV DIRECTIVE

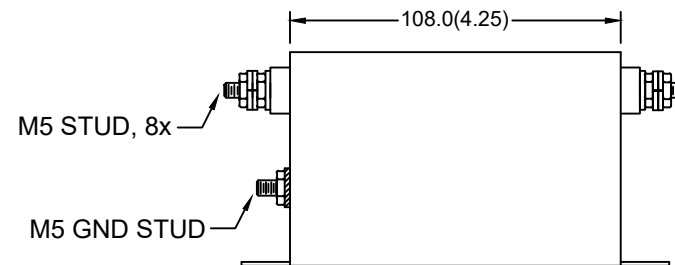
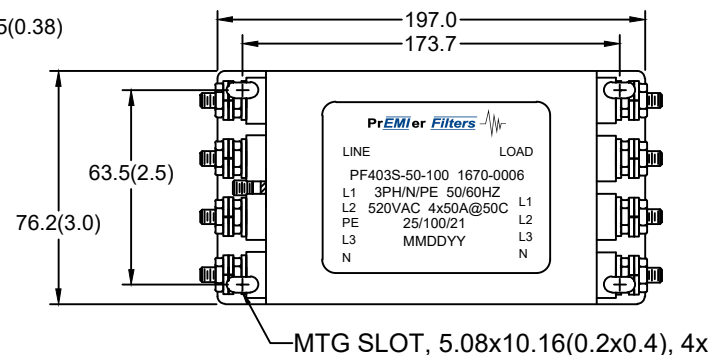
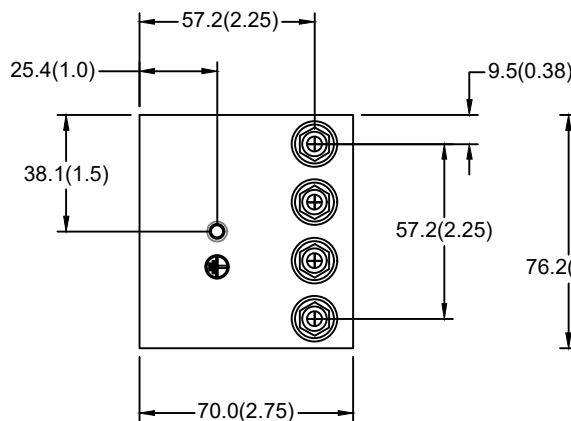

SCHEMATIC

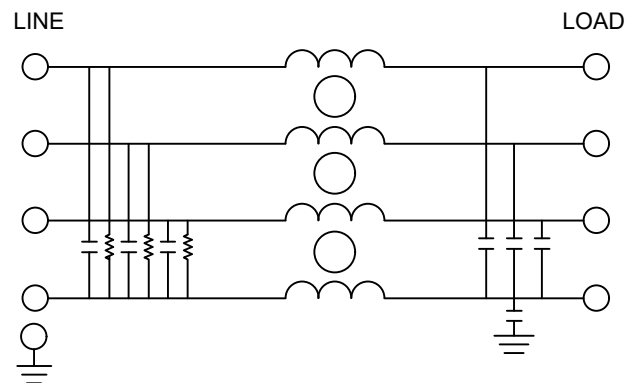

TYPICAL INSERTION LOSS, 50/50 OHM

FREQ(HZ)	150K	500K	1M	10M	30M
CM, dB	48	56	62	50	40
DM, dB	46	70	72	66	50